

2-2 TELLEGEN'S THEOREM

Next, an important law of circuit theory, *Tellegen's theorem*, will be introduced. This basic theorem will help us understand the fundamental properties of physically realizable impedance functions discussed later in this chapter. It will also be used much later in the book (in Chaps. 9 and 10) in connection with the sensitivity analysis of circuits.

Consider the circuit shown in Fig. 2-4a. With the notations of Fig. 2-4b, the Kirchhoff current laws (KCL) give

$$\begin{aligned} j_1 + j_2 + j_5 &= 0 \\ -j_2 + j_3 + j_4 &= 0 \\ -j_4 - j_5 + j_6 &= 0 \end{aligned} \quad (2-27)$$

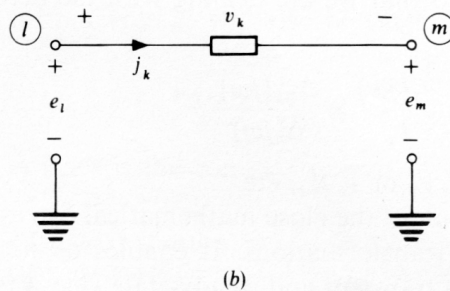
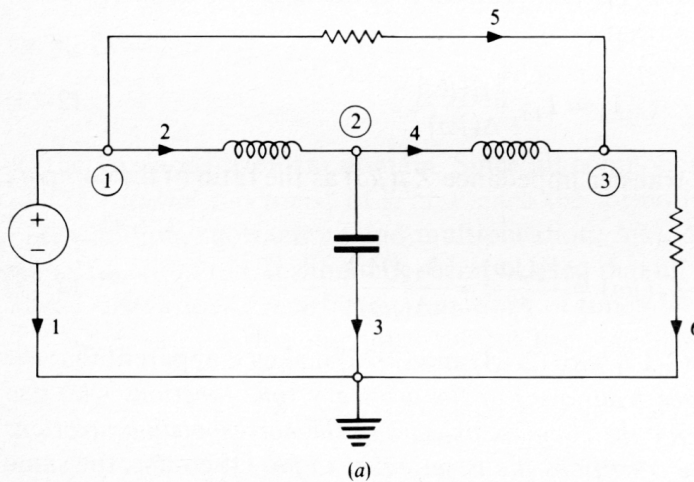

Figure 2-4 (a) Linear circuit; (b) notations used in the analysis

Note the use of *associated directions*¹ for v_k and j_k . Equations (2-27) can also be written in the form†

$$\mathbf{A}\mathbf{j} = \mathbf{0} \quad (2-28)$$

where \mathbf{A} is the *incidence matrix*

$$\mathbf{A} = \begin{bmatrix} 1 & 1 & 0 & 0 & 1 & 0 \\ 0 & -1 & 1 & 1 & 0 & 0 \\ 0 & 0 & 0 & -1 & -1 & 1 \end{bmatrix} \begin{matrix} 1 \\ 2 \\ 3 \end{matrix} \quad (2-29)$$

The elements of \mathbf{A} are given by

$$a_{ij} = \begin{cases} +1 & \text{if branch } j \text{ leaves node } i \\ -1 & \text{if branch } j \text{ enters node } i \\ 0 & \text{if branch } j \text{ is not incident with node } i \end{cases} \quad (2-30)$$

Similarly, from the Kirchhoff voltage law (KVL)

$$\begin{aligned} v_1 &= e_1 \\ v_2 &= e_1 - e_2 \\ v_3 &= e_2 \\ v_4 &= e_2 - e_3 \\ v_5 &= e_1 - e_3 \\ v_6 &= e_3 \end{aligned} \quad (2-31)$$

or, using (2-29),

$$\mathbf{v} = \mathbf{A}^T \mathbf{e} \quad (2-32)$$

where \mathbf{A}^T denotes the transpose of \mathbf{A} . Equations (2-28) and (2-32) are, of course, the general matrix forms of the KCL and KVL, respectively.¹

Since all relations (2-27) to (2-32) involve only additions and subtractions, they remain valid if we perform any linear operations on the j_i , v_k , and e_l . For example, they hold also for the Laplace transforms $J_i(s)$, $V_k(s)$, and $E_l(s)$ or for the phasors J_i , V_k , and E_l , etc.

Let the branch power $v_k j_k$ be summed for all N branches of the circuit. Then, by (2-32) and (2-28),

$$\sum_{k=1}^N v_k j_k = \mathbf{v}^T \mathbf{j} = (\mathbf{A}^T \mathbf{e})^T \mathbf{j} = \mathbf{e}^T (\mathbf{A}\mathbf{j}) = 0 \quad (2-33)$$

Here the familiar rules $(\mathbf{A}\mathbf{e})^T = \mathbf{e}^T \mathbf{A}^T$, $(\mathbf{A}^T)^T = \mathbf{A}$, and $\mathbf{e}^T \mathbf{0} = 0$ of vector algebra have been used.

Equation (2-33) is equivalent, of course, to the conservation of power in the circuit, and thus its emergence from Kirchhoff's laws is not too surprising.

† Here, and in the rest of the book, \mathbf{x} denotes a column vector and \mathbf{A} denotes a matrix.

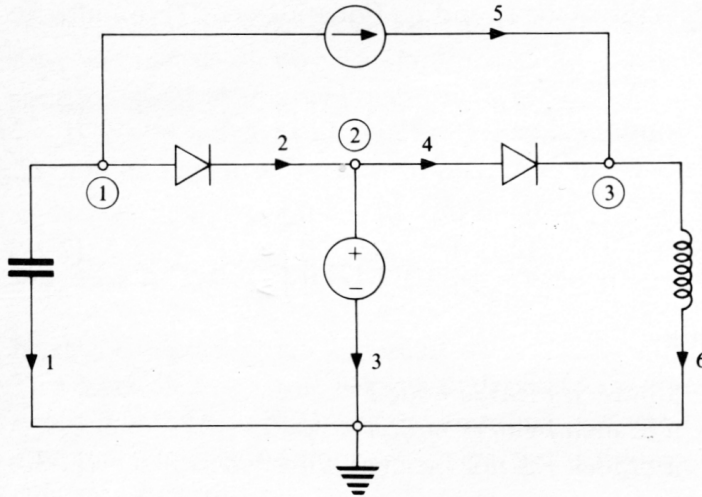

Figure 2-5 Circuit with the same configuration as that of Fig. 2-4 but with different elements.

Consider, however, the circuit of Fig. 2-5, which has the same topological configuration, same reference directions and numbering, and hence the same \mathbf{A} as the circuit of Fig. 2-4. Hence, all the equations (2-27) to (2-32) remain valid for this circuit as well, with \mathbf{A} remaining the same. Let the electric quantities of the circuit of Fig. 2-5 be \mathbf{j}' , \mathbf{v}' , and \mathbf{e}' . Then

$$\mathbf{A}\mathbf{j}' = \mathbf{0} \quad (2-34)$$

and
$$\mathbf{v}' = \mathbf{A}^T \mathbf{e}' \quad (2-35)$$

hold.

Next, let the physically meaningless quantity $\sum_{k=1}^N v_k j'_k$ be found:

$$\sum_{k=1}^N v_k j'_k = \mathbf{v}^T \mathbf{j}' = (\mathbf{A}^T \mathbf{e}')^T \mathbf{j}' = \mathbf{e}^T (\mathbf{A} \mathbf{j}') = 0 \quad (2-36)$$

where (2-32) and (2-34) were used. While the left-hand side of (2-36) does have the dimension of watts, it does not correspond to physical power since v_k and j'_k exist in two different circuits.

An entirely analogous derivation gives

$$\sum_{k=1}^N v'_k j_k = \mathbf{v}'^T \mathbf{j} = 0 \quad (2-37)$$

Equations (2-36) and (2-37) are general forms and (2-33) is a special form of *Tellegen's theorem*. The general forms have great significance (as will be shown in Chaps. 9 and 10) in the calculation of circuit sensitivities.

Consider now a linear passive RLCM one-port (Fig. 2-6). By (2-32), using Laplace transformation,

$$\mathbf{V}(s) = \mathbf{A}^T \mathbf{E}(s) \quad (2-38)$$

Physical proof:

Construct a new network N' with the same topology. Choose a tree. Put voltage sources in the tree branches, whose value equal the corresponding branch voltages of N , and put current sources in the links whose values equal the corresponding link of N .

Thus, conservation of power gives Tellegen's theorem.

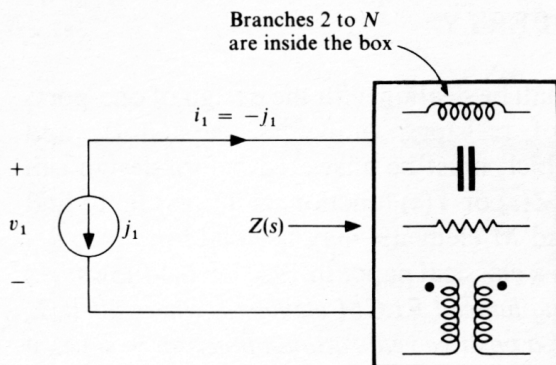

Figure 2-6 RLCM one-port.

and from (2-28), using Laplace transformation and taking the complex conjugate,

$$\mathbf{A}\mathbf{J}^*(s) = \mathbf{0} \quad (2-39)$$

Hence
$$\mathbf{V}^T \mathbf{J}^* = \mathbf{E}^T \mathbf{A} \mathbf{J}^* = 0 \quad (2-40)$$

or
$$\sum_{k=1}^N V_k(s) J_k^*(s) = 0 \quad (2-41)$$

From Fig. 2-6 and Eq. (2-41), using $i_1 = -j_1$, we get

$$-V_1(s) J_1^*(s) = V_1(s) I_1^*(s) = \sum_{k=2}^N V_k J_k^* \quad (2-42)$$

Note that branches 2 to N are *inside* the one-port.

Defining the *impedance* of the one-port as the ratio of $V_1(s)$ and $I_1(s)$,

$$Z(s) \triangleq \frac{V_1(s)}{I_1(s)} = \frac{V_1(s) I_1^*(s)}{I_1(s) I_1^*(s)} = \frac{V_1(s) I_1^*(s)}{|I_1(s)|^2}$$

leads to

$$Z(s) = \frac{1}{|I_1(s)|^2} \sum_{k=2}^N V_k(s) J_k^*(s) \quad (2-43)$$

It is easy to show, using an entirely analogous derivation, that the dual relation

$$Y(s) \triangleq \frac{I_1(s)}{V_1(s)} = \frac{1}{|V_1(s)|^2} \sum_{\text{all internal branches}} V_k^*(s) J_k(s) \quad (2-44)$$

holds for the input *admittance* $Y(s)$ of the one-port.

Equations (2-43) and (2-44) are fundamental to the analysis and design of one-ports, as will be shown in the next section.

Network Functions

Driving-Point and Transfer Functions for Linear Networks

Node equations: $\underline{Y}_n(s)\underline{E}(s) = \underline{J}_n(s)$ can (in principle) be solved using Cramer’s Rule, so that the node voltages are given by

$$\underline{E}(s) = \underline{Y}_n^{-1}(s)\underline{J}_n(s) \tag{a}$$

$$\underline{Y}_n \underline{E} = \underline{J}_n = \underline{A}(\underline{J} - \underline{Y}V_e) \tag{b}$$

Where the ij element of the inverse matrix is $\frac{\Delta_{ij}}{\Delta}$, Δ being the determinant of \underline{Y}_n and Δ_{ij} its ij cofactor (signed subdeterminant). For a lumped linear circuit, Δ and the Δ_{ij} are all real and rational in s .

It follows from equation (a) that all response voltages and currents are weighted sums of the excitations, which enter $\underline{J}_n(s)$.

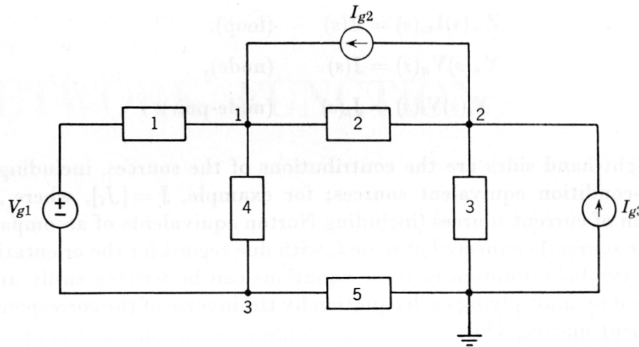

Fig. 1. Illustration for equivalent sources.

example:

Lumped Linear Network

$$\mathbf{J} = \begin{bmatrix} J_1 \\ J_2 \\ J_3 \end{bmatrix} = \begin{bmatrix} I_{g2} + Y_1 V_{g1} \\ -I_{g2} + I_{g3} \\ -Y_1 V_{g1} \end{bmatrix}$$

Nodal current

Excitation vector

$$V_k(s) = \left(\frac{Y_1 \Delta_{1k} - Y_1 \Delta_{3k}}{\Delta} \right) V_{g1} + \left(\frac{\Delta_{1k} - \Delta_{2k}}{\Delta} \right) I_{g2} + \left(\frac{\Delta_{2k}}{\Delta} \right) I_{g3} \quad k = 1, 2, 3$$

$$\underline{E}(s) = \begin{bmatrix} \Delta_{11} & \Delta_{12} & \Delta_{13} \\ \Delta_{21} & \Delta_{22} & \Delta_{23} \\ \Delta_{31} & \Delta_{32} & \Delta_{33} \end{bmatrix} \frac{\underline{J}(s)}{\Delta}$$

Superposition

Driving-Point Functions (Immittances)

One-port circuit:

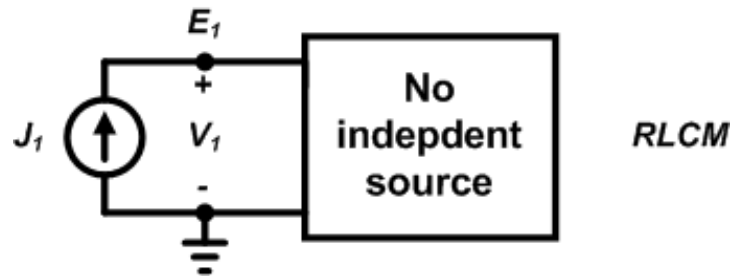

Driving-point impedance:

$$Z(s) = \frac{V_1(s)}{I_1(s)}$$

Driving-point admittance:

$$Y(s) = \frac{I_1(s)}{V_1(s)} = \frac{1}{Z(s)}$$

From (a), $Z(s) = \frac{\Delta_{11}(s)}{\Delta(s)}$; a real rational function of s .The positive real (PR) property: $Z(s)$ is a PR function of s if $\Re\{Z(s)\} \geq 0$ for $\Re\{s\} \geq 0$ Brune's Theorem:Any real rational PR $Z(s)$ can be realized using physical RLCM elements (R, L, C all ≥ 0), and vice versa, any such physical impedance must satisfy the real rational PR conditions.Proof of the PR property:Consider a circuit containing only $R, L,$ and C elements. For an $R, V = R \cdot J$, so $V \cdot J^* = R \cdot |J|^2$. Similarly, for an $L, V \cdot J^* = sL \cdot |J|^2$, and for a $C, V \cdot J^* = \frac{1}{sC} \cdot |J|^2$. Hence, for the complete network, substituting into Tellegen's Theorem with $J_1 = 1A$.

$$Z(s) = \sum_k V_k(s) J_k^*(s) = F_o(s) + \frac{1}{s} V_o(s) + s T_o(s)$$

Where,

$$F_o(s) = \sum_k R_k |J_k|^2, \quad V_o(s) = \sum_k \frac{|J_k|^2}{C_k}, \quad \text{and} \quad T_o(s) = \sum_k L_k |J_k|^2$$

For a physical circuit, all R_k, L_k, C_k are non-negative real numbers, and hence so are $F_o, V_o,$ and $T_o,$ for any s .

Next let

$$s = \sigma + j\omega$$

$$\frac{1}{\sigma + j\omega} = \frac{\sigma - j\omega}{\sigma^2 + \omega^2} \Rightarrow \frac{\sigma}{\sigma^2 + \omega^2} \geq 0$$

Where $\sigma \geq 0$. Then both $\Re e(s)$ and $\Re e\left(\frac{1}{s}\right) = \frac{\sigma}{\sigma^2 + \omega^2}$ are non-negative, and hence so is $\Re e Z(s)$.

The above can be extended to transformers.

The proof of the sufficiency of the real rational PR conditions is based on a synthesis, which always leads to physical element values. It uses resistors, capacitors and closely coupled transformers.

Brune synthesis

$$\frac{s^2 + \dots s + 3}{s^5 + \dots 2s + 1}$$

Closely coupled “physical transformer”

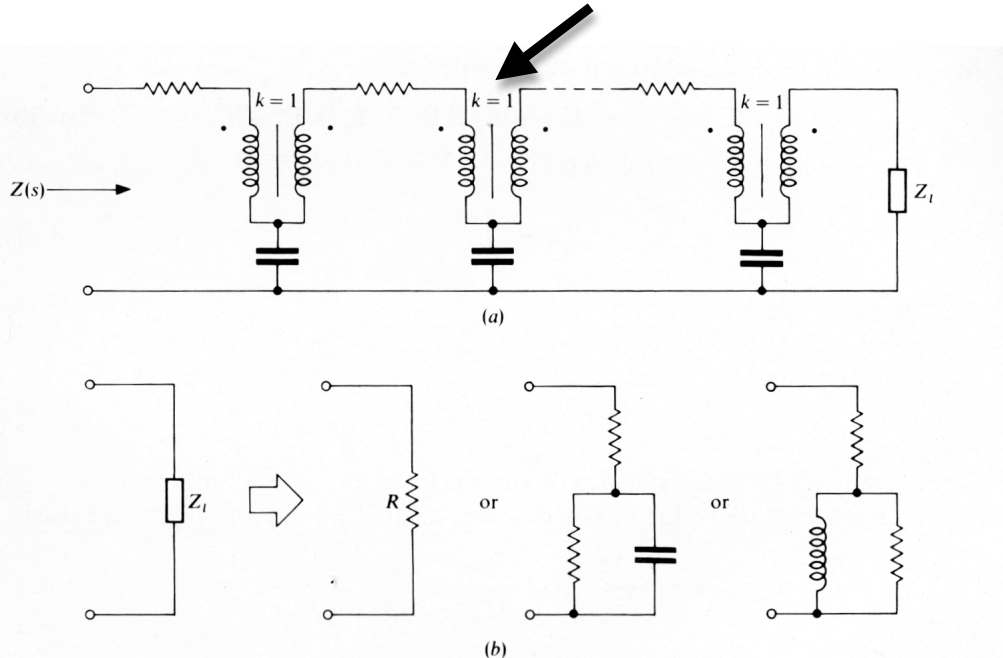

Figure 4-12 (a) Brune realization of an impedance $Z(s)$; (b) realizations for the last impedance Z_i .

Node Analysis Summary

\underline{A}	Incidence matrix, all analysis in s domain
-----------------	--

Kirchhoff's Laws:

$\underline{V} = \underline{A}' \underline{E}$	\underline{V} : branch voltage vector \underline{E} : node voltage vector
$\underline{A} \underline{I} = \underline{0}$	\underline{I} : branch current vector $\underline{0}$: zero vector

Branch Relations:

$\underline{I}' = \underline{I} - \underline{J}$	\underline{I}' : branch current vector \underline{I} : element current vector \underline{J} : source current vector
$\underline{V}' = \underline{V} - \underline{V}_E$	\underline{V}' : branch voltage vector \underline{V} : element voltage vector \underline{V}_E : source voltage vector
$\underline{I} = \underline{Y} \underline{V}$	\underline{Y} : branch admittance matrix

Combining relations:

$\underline{Y}_N = \underline{A} \underline{Y} \underline{A}'$	\underline{Y}_N : node admittance matrix
$\underline{J}_N = \underline{A} [\underline{J} - \underline{Y} \underline{V}]$	\underline{J}_N : node current excitation vector
$\underline{Y}_N \underline{E} = \underline{J}_N$	generalized node equations